



Cambridge IGCSE™

CANDIDATE
NAME

CENTRE
NUMBER

--	--	--	--	--

CANDIDATE
NUMBER

--	--	--	--



CO-ORDINATED SCIENCES

0654/51

Paper 5 Practical Test

May/June 2021

2 hours

You must answer on the question paper.

You will need: The materials and apparatus listed in the confidential instructions

INSTRUCTIONS

- Answer **all** questions.
- Use a black or dark blue pen. You may use an HB pencil for any diagrams or graphs.
- Write your name, centre number and candidate number in the boxes at the top of the page.
- Write your answer to each question in the space provided.
- Do **not** use an erasable pen or correction fluid.
- Do **not** write on any bar codes.
- You may use a calculator.
- You should show all your working and use appropriate units.

INFORMATION

- The total mark for this paper is 60.
- The number of marks for each question or part question is shown in brackets [].
- Notes for use in qualitative analysis are provided in the question paper.

For Examiner's Use	
1	
2	
3	
4	
5	
6	
7	
Total	

This document has **20** pages. Any blank pages are indicated.

1 You are going to investigate the movement of coloured water in a celery stem.

(a) Procedure

- Take the piece of celery and cut it approximately in half as shown in Fig. 1.1.

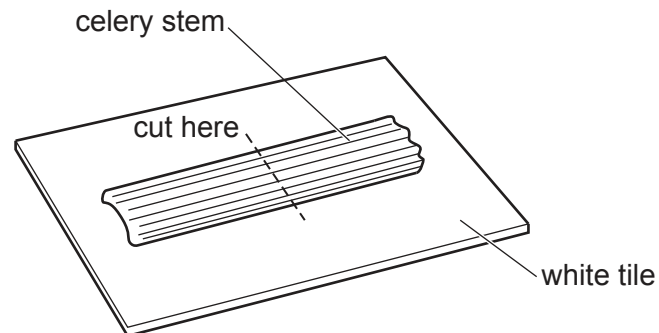

Fig. 1.1

- Place one half with the freshly cut end in the coloured water as shown in Fig. 1.2.

Leave for at least five minutes. Continue with the question while you are waiting.

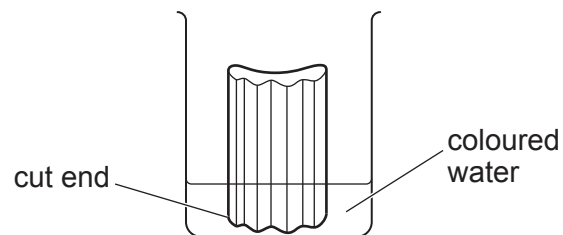

Fig. 1.2

- (i) In the box provided, make an enlarged detailed pencil drawing of the cut end of the celery from the white tile. It may help you to use the hand lens.



[3]

(ii) Procedure

- After five minutes, remove the piece of celery from the coloured water and blot it dry.
- Cut a 2 mm slice from the end that was in the coloured water.
- Place this slice on the white tile with the newly cut surface facing upwards.
- Examine this upper surface using the hand lens.

On your drawing from **(a)(i)**, use a label line to label with an **X** one of the areas that is now stained. [1]

- (iii)** The stained areas are xylem tissue.

State what can be concluded about the function of the xylem tissue.

..... [1]

- (b) A student measures and records the movement of coloured water into a celery stem over five hours.

Their results are shown in Table 1.1.

Table 1.1

time taken/hours	distance moved/mm
0	0
1	21
2	39
3	60
4	82
5	97

- (i) On the grid provided, plot a graph of distance moved (vertical axis) against time taken.

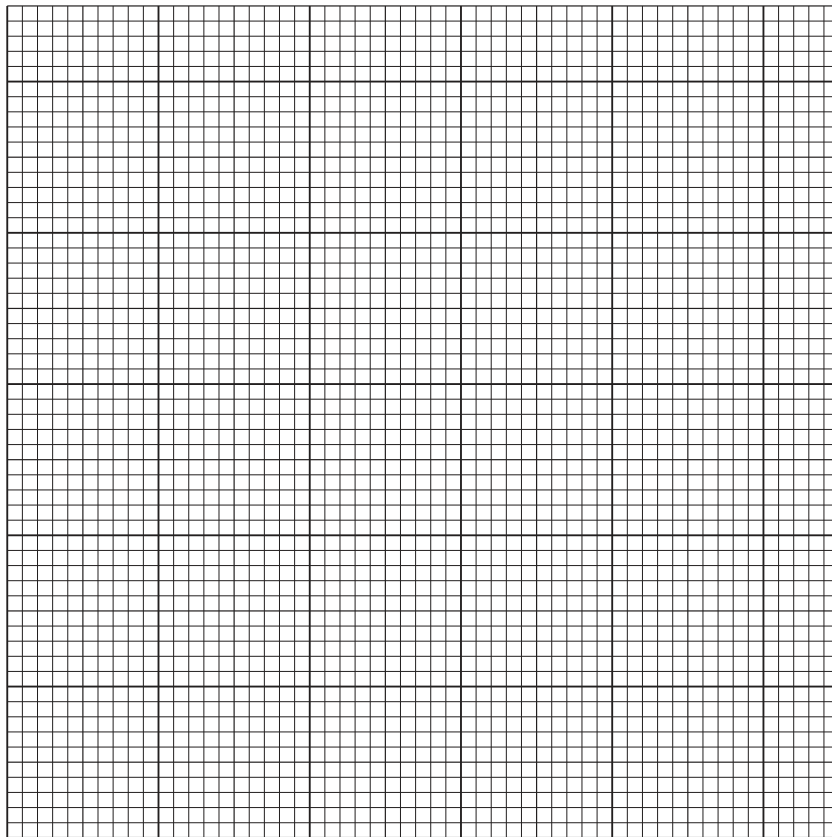

- (ii) Draw the best-fit straight line. [3]
- (iii) Use your graph to determine the distance moved by the coloured water after 1.5 hours. [1]
- Indicate on your graph how you arrived at your answer.

distance moved = mm [2]

(iv) Describe the relationship between the distance moved by the coloured water and the time taken.

.....

..... [1]

[Total: 12]

2 You are going to test some celery for its nutrient content.

(a) Procedure

- Pour about 1 cm depth of celery puree into each of three test-tubes.
 - To one test-tube add an equal amount of Benedict's solution, shake well and place in the hot water-bath provided for about three minutes.
Continue with the procedure while you are waiting.
 - To the second test-tube add an equal amount of biuret solution.
 - To the third test-tube add a few drops of iodine solution.
- (i) Observe and record in Table 2.1 the final colour in each test-tube.

Table 2.1

food test	final colour observed	conclusion
Benedict's solution		
biuret solution		
iodine solution		

[3]

(ii) Complete Table 2.1 by writing a conclusion for each of the three tests.

[3]

(b) (i) A student tests the celery for the presence of fat.

State the two substances needed for the fat test.

..... and [1]

(ii) Explain why there should be no flames in the laboratory when doing this test.

..... [1]

[Total: 8]

- 3 In this investigation you are going to design a test to distinguish between sodium hydrogencarbonate and sodium carbonate.

(a) Procedure

- Place 1 cm depth of aqueous sodium hydrogencarbonate into each of four test-tubes.
- Place a wooden splint into the first test-tube and leave it soaking until needed.
- Add a few drops of methyl orange indicator to the second test-tube and record your observation in Table 3.1.
- Add 1 cm depth of dilute hydrochloric acid to the third test-tube and test the gas given off. Record in Table 3.1 your observation, the gas test used and the identity of the gas.
- Add 1 cm depth of aqueous magnesium chloride to the fourth test-tube. Record your observation in Table 3.1.
- Place the splint from the first test-tube into the top of a blue Bunsen burner flame. Record in Table 3.1 the first colour seen.

Repeat the procedure using aqueous sodium carbonate instead of aqueous sodium hydrogencarbonate.

Table 3.1

	aqueous sodium hydrogencarbonate	aqueous sodium carbonate
colour with methyl orange		
observation when dilute hydrochloric acid added		
test for the gas given off		
identity of gas		
observation when aqueous magnesium chloride added		
flame test colour		

[6]

- (b)** A colourless solution is either sodium hydrogencarbonate or sodium carbonate.

Use the results in Table 3.1 to describe a test to identify the solution as either sodium hydrogencarbonate or sodium carbonate.

.....

 [1]

[Total: 7]

4 You are going to investigate the effect of surface area on the rate of a reaction.

Marble chips react with dilute hydrochloric acid to make carbon dioxide gas.

You will use three forms of marble chips. Each form has a different surface area.

large marble chips	small surface area
small marble chips	↓
powdered marble chips	large surface area

(a) Procedure

- Place about 6 cm depth of dilute hydrochloric acid into a boiling tube (large test-tube).
- Set up the apparatus shown in Fig. 4.1.
- Add three large marble chips to the acid and quickly replace the bung.
- Start the timer immediately.
- Stop the timer when the test-tube is filled with gas.
- If it takes longer than three minutes then record the time as >180 s.
- Record the time in Table 4.1.
- Pour the contents of the boiling tube into the waste container.

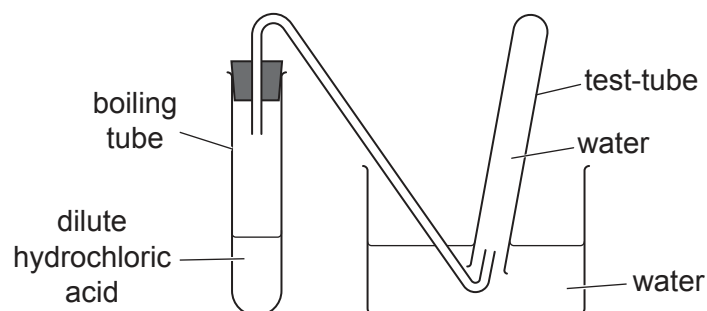

Fig. 4.1

Repeat the procedure using seven small marble chips.

Repeat the procedure using two spatulas of powdered marble chips. You will need to be very quick replacing the bung.

Table 4.1

	time to fill one test-tube with gas/s
large marble chips	
small marble chips	
powdered marble chips	

[3]

(b) State the relationship between surface area and **rate** of reaction.

.....
..... [1]

(c) Suggest a different method of collecting and measuring the gas produced.

Name the apparatus and explain how the rate of reaction is measured.

.....
.....
..... [2]

[Total: 6]

5 Pure water has a fixed boiling temperature of 100 °C.

When an impurity such as salt is added to water the boiling temperature increases.

Plan an experiment to find out if the amount of salt added to water is proportional to the increase in boiling temperature of the water.

You may use any common laboratory apparatus and samples of water and salt.

You will **not** be doing this experiment.

Include in your plan:

- the apparatus needed
- a brief description of the method, explaining any safety precautions
- the measurements you will make, including how to make them as accurate as possible
- the variables you will control
- how you will process your results and use them to draw a conclusion.

You may include a labelled diagram if you wish.

You may also include a table that can be used to record results if you wish. You are **not** required to include any results.

..... [7]

[Total: 7]

- 6 You are going to investigate how the potential difference V across a lamp and the power P of the lamp change as the length l of a resistance wire in series with the lamp changes.

The circuit shown in Fig. 6.1 has been set up for you.

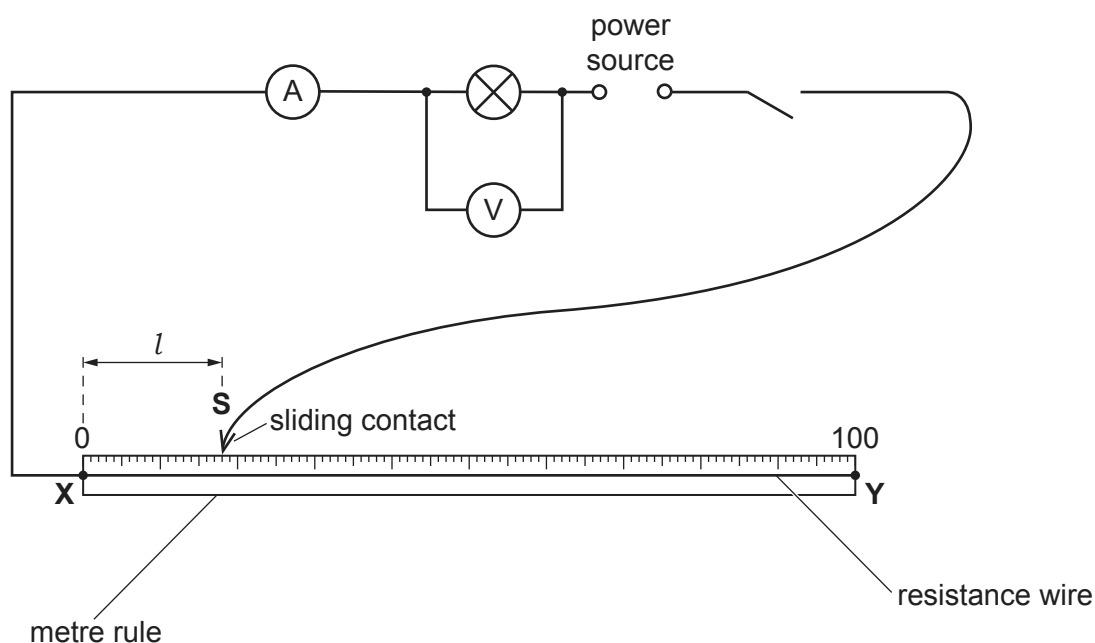

Fig. 6.1

(a) Procedure

- Close the switch.
- Place the sliding contact **S** on the resistance wire at a distance $l = 15.0$ cm from **X**.

(i) Record in Table 6.1:

- the current I flowing through the lamp
- the potential difference V across the lamp.

Open the switch.

Table 6.1

length l /cm	current I /A	potential difference V /V	power P /.....
15.0			
30.0			
45.0			
60.0			

[2]

- (ii) Repeat the procedure in (a) for values of $l = 30.0$ cm, 45.0 cm and 60.0 cm.

Record in Table 6.1 the current I and the potential difference V for each length.

[3]

- (b) (i) Calculate the power P of the lamp for each length of wire.

Use the equation shown.

$$P = V \times I$$

Record in Table 6.1 your values of P to an appropriate number of significant figures. [2]

- (ii) Complete the column heading in Table 6.1 by giving the unit for power. [1]

- (iii) State what you observe, when doing the experiment, which shows that the power P of the lamp decreases as the length l of resistance wire increases.

.....
..... [1]

- (c) A student suggests that the potential difference V across the lamp is proportional to the length l of resistance wire in the circuit.

State if your values in Table 6.1 support this suggestion.

Justify your statement by referring to the values.

statement

justification

..... [1]

[Total: 10]

7 You are going to use a spring to measure the mass and density of a stone.

A spring has been set up in a clamp for you, as shown in Fig. 7.1.

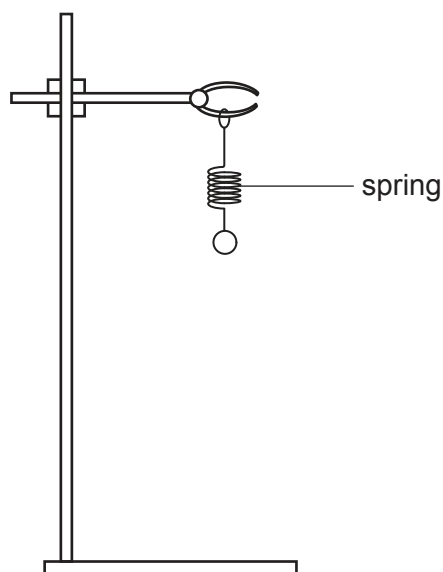

Fig. 7.1

- (a) (i) Measure and record the length l_0 of the unstretched spring in centimetres to the nearest millimetre. Do not include the loops at the ends of the spring.

$$l_0 = \dots\dots\dots \text{ cm [1]}$$

- (ii) Use a double-headed arrow (\longleftrightarrow) to show **on Fig. 7.1** the length l_0 that you measured. [1]

- (b) (i) **Procedure**

- Suspend a mass m of 200g on the spring.
- Measure the new length l_M of the spring in centimetres to the nearest millimetre.

$$l_M = \dots\dots\dots \text{ cm [1]}$$

- (ii) Calculate the extension e of the spring.

Use the equation shown.

$$e = (l_M - l_0)$$

$$e = \dots\dots\dots \text{ cm [1]}$$

(c) Procedure

- Remove the 200 g mass from the spring.
- Attach the stone provided to the spring.

(i) Measure the new length l_A of the spring.

$$l_A = \dots\dots\dots \text{ cm}$$

Calculate the extension e_A of the spring caused by the stone.

Use the equation shown.

$$e_A = (l_A - l_0)$$

$$e_A = \dots\dots\dots \text{ cm} \quad [1]$$

(ii) Calculate the mass m of the stone.

Use the equation shown.

$$m = \frac{200 \times e_A}{e}$$

$$m = \dots\dots\dots \text{ g} \quad [1]$$

(d) Procedure

- Place the beaker of water under the stone.
- Slowly lower the clamp until the stone is just completely immersed in the water, as shown in Fig. 7.2.

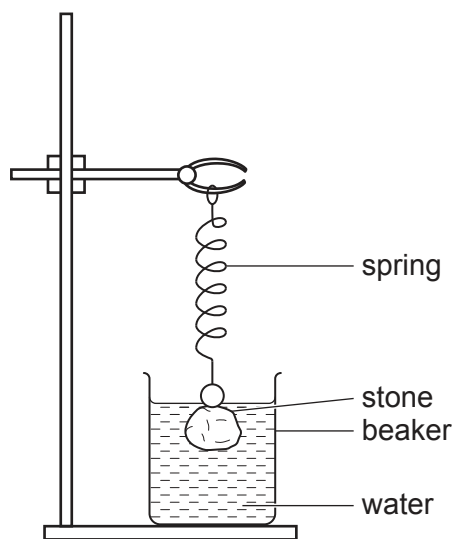

Fig. 7.2

Measure the new length l_W of the spring.

$l_W = \dots\dots\dots$ cm

Calculate the extension e_W of the spring.

Use the equation shown.

$$e_W = (l_W - l_0)$$

$e_W = \dots\dots\dots$ cm
[1]

(e) Use your answers to (c)(i) and (d) to calculate the density d of the stone.

Use the equation shown.

$$d = \frac{e_A}{(e_A - e_W)}$$

density d of stone = $\dots\dots\dots$ g/cm³ [1]

(f) (i) It is important to avoid a line-of-sight (parallax) error when measuring the length of the spring.

Describe how you avoided this error.

$\dots\dots\dots$
 $\dots\dots\dots$ [1]

(ii) To obtain a more accurate length, suggest **one** other precaution or improvement to the procedure that can be made.

$\dots\dots\dots$
 $\dots\dots\dots$ [1]

[Total: 10]

NOTES FOR USE IN QUALITATIVE ANALYSIS

Tests for anions

<i>anion</i>	<i>test</i>	<i>test result</i>
carbonate (CO_3^{2-})	add dilute acid	effervescence, carbon dioxide produced
chloride (Cl^-) [in solution]	acidify with dilute nitric acid, then add aqueous silver nitrate	white ppt.
bromide (Br^-) [in solution]	acidify with dilute nitric acid, then add aqueous silver nitrate	cream ppt.
nitrate (NO_3^-) [in solution]	add aqueous sodium hydroxide then aluminium foil; warm carefully	ammonia produced
sulfate (SO_4^{2-}) [in solution]	acidify, then add aqueous barium nitrate	white ppt.

Tests for aqueous cations

<i>cation</i>	<i>effect of aqueous sodium hydroxide</i>	<i>effect of aqueous ammonia</i>
ammonium (NH_4^+)	ammonia produced on warming	–
calcium (Ca^{2+})	white ppt., insoluble in excess	no ppt., or very slight white ppt.
copper (Cu^{2+})	light blue ppt., insoluble in excess	light blue ppt., soluble in excess, giving a dark blue solution
iron(II) (Fe^{2+})	green ppt., insoluble in excess	green ppt., insoluble in excess
iron(III) (Fe^{3+})	red-brown ppt., insoluble in excess	red-brown ppt., insoluble in excess
zinc (Zn^{2+})	white ppt., soluble in excess giving a colourless solution	white ppt., soluble in excess, giving a colourless solution

Tests for gases

<i>gas</i>	<i>test and test result</i>
ammonia (NH_3)	turns damp, red litmus paper blue
carbon dioxide (CO_2)	turns limewater milky
chlorine (Cl_2)	bleaches damp litmus paper
hydrogen (H_2)	'pops' with a lighted splint
oxygen (O_2)	relights a glowing splint

Flame tests for metal ions

<i>metal ion</i>	<i>flame colour</i>
lithium (Li^+)	red
sodium (Na^+)	yellow
potassium (K^+)	lilac
copper(II) (Cu^{2+})	blue-green

Permission to reproduce items where third-party owned material protected by copyright is included has been sought and cleared where possible. Every reasonable effort has been made by the publisher (UCLES) to trace copyright holders, but if any items requiring clearance have unwittingly been included, the publisher will be pleased to make amends at the earliest possible opportunity.

To avoid the issue of disclosure of answer-related information to candidates, all copyright acknowledgements are reproduced online in the Cambridge Assessment International Education Copyright Acknowledgements Booklet. This is produced for each series of examinations and is freely available to download at www.cambridgeinternational.org after the live examination series.

Cambridge Assessment International Education is part of the Cambridge Assessment Group. Cambridge Assessment is the brand name of the University of Cambridge Local Examinations Syndicate (UCLES), which itself is a department of the University of Cambridge.